

Model DINO

« DINOPLEX C » ELECTRONIC IGNITION DEVICE

General.

The « Dinoplex C » electronic ignition device installed on the FIAT DINO Coupé and Spider is so designed as to warrant a most positive ignition under any operation condition inasmuch as this unit supplies the spark-plugs with a spark discharge power far more intense than supplied by the conventional ignition system.

The electronic ignition system (i.e., of the capacitive discharge type) prevents the misfiring troubles likely to

occur with the conventional system under given operation conditions and permits an easier engine tune-up along with the possibility of using a single grade of plugs, suitably cold, for both town and highway driving.

The « Dinoplex C » unit is installed on the Coupé starting from the car with No. for Spares 0002466 and on the Spider starting from car with No. for Spares 000833.

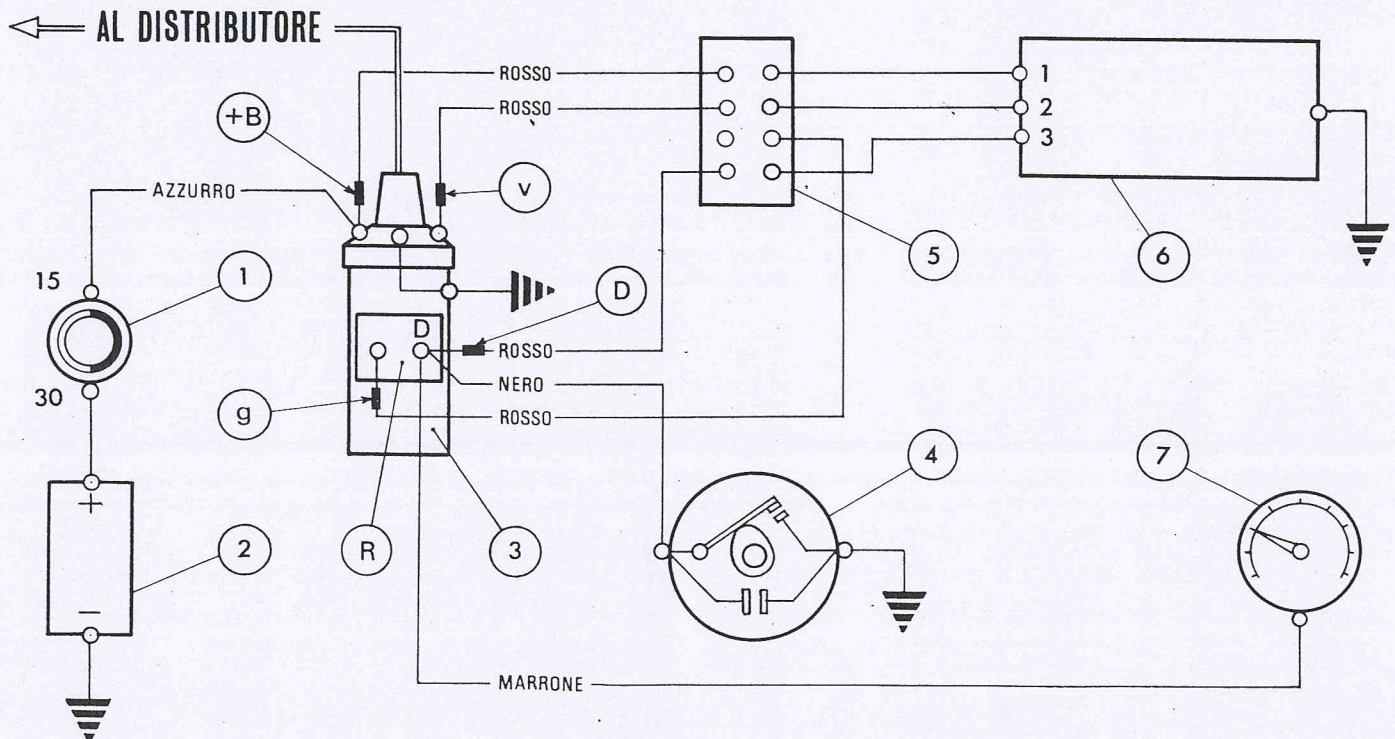

Fig. 1. - « Dinoplex C » Wiring diagram (DINO Coupé and Spider Versions).

1. Lock switch - 2. Battery - 3. Ignition coil - 4. Ignition distributor breaker - 5. Change-over switch for shifting from « NORMAL » to « EMERGENCY » ignition - 6. Electronic ignition unit - 7. Electronic tachometer - R. Additional resistor - + B and D - Identification marks on the leads from the « Dinoplex C » unit - g. Yellow identification mark - v. Green identification mark.

Al distributore = To distributor - Rosso = Red - Azzurro = Light blue - Nero = Black - Marrone = Brown.

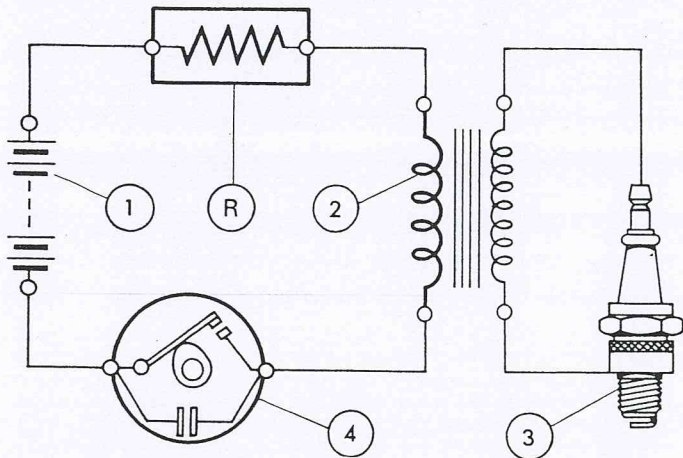

Fig. 2. - Traditional ignition system layout.

1. Battery - 2. Ignition coil - 3. Spark plug - 4. Ignition distributor breaker - R. Additional resistor.

Characteristics and operation (reference to fig. 3).

The «Dinoplex C» unit consists mainly of the following components:

- 1) A d.c. voltage step-up unit, 7.
- 2) A capacitor, 10.
- 3) A thyristor, 8.
- 4) An ignition coil, 3, modified in the connections.

Operation is as follows:

Step-up unit 7, consisting of an inverter and a rectifying bridge raises the tension from 12 V to about 500 V.

This voltage charges capacitor 10 connected to the ignition coil through the Thyristor diode 8 controlled by the impulses fed by breaker arm 4 of the ignition distributor, the impulses being in turn controlled by adaptor 9.

Diode 8 permits capacitor 10 to discharge quickly into ignition coil primary winding.

A 40,000 V current is thus generated in coil secondary winding and this high tension is fed to the sparkplugs, through the ignition distributor, at a potential much greater than with the conventional system.

The new electronic ignition system, however, does not exclude the conventional system which can be inserted, in emergencies, by change-over switch 5 which throws out the electronic system.

Comparison of the two ignition systems.

Fig. 2 is the layout of the traditional ignition system; and fig. 3 the layout of the «Dinoplex C» electronic system.

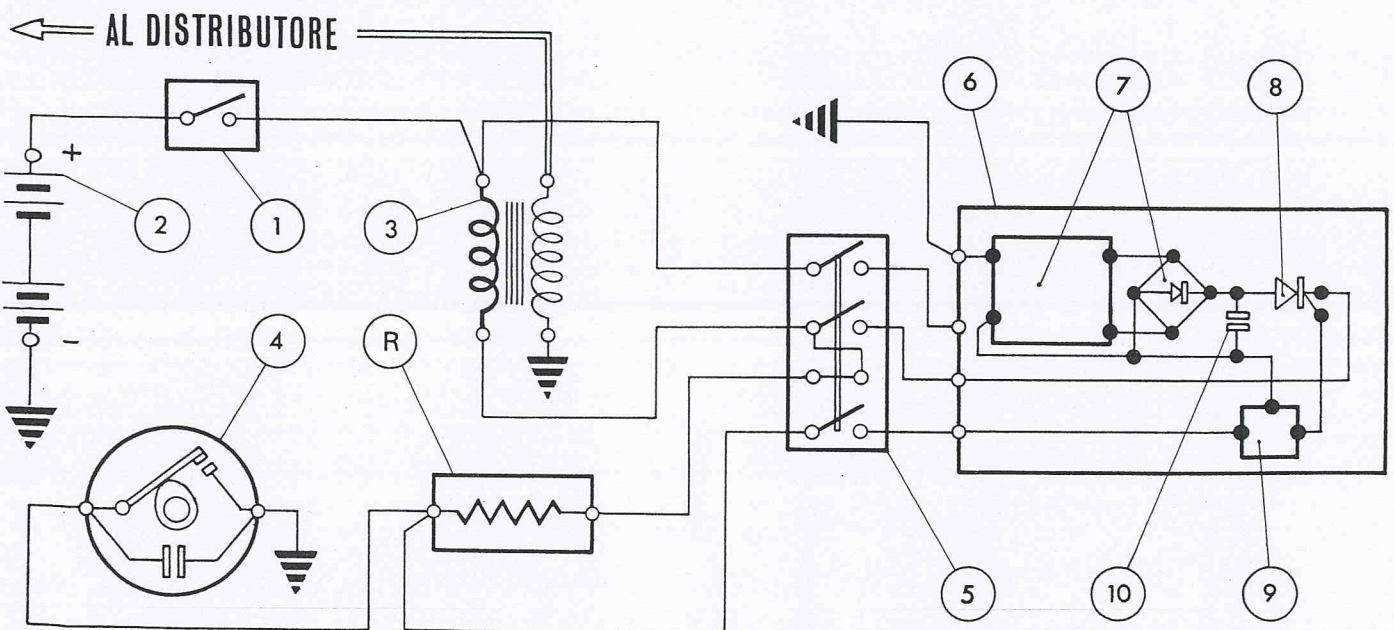

Fig. 3. - «Dinoplex C» electronic ignition system layout.

1. Lock switch - 2. Battery - 3. Ignition coil - 4. Ignition distributor breaker - 5. Change-over switch for shifting from «NORMAL» to «EMERGENCY» ignition - 6. Electronic ignition unit - 7. Voltage step-up-inverter unit - 8. Thyristor - 9. Electronic adapter of breaker (4) impulses - 10. Discharge capacitor - R. Additional resistor.

Al distributore = To distributor.

The main differences of the electronic ignition system are given, as it is readily apparent from the two diagrams, by the specific electronic unit and, additionally, by:

- the ignition coil whose connections are modified (when the electronic ignition device is inserted, additional resistor R, figs. 2-3, on the coil and in series with coil primary winding is cut-off);
- the presence of change-over switch 5, fig. 3, which permits to shift from one type of ignition to the other.

Notes for repairs.

The « Dinoplex C » is a « **sealed** » unit and in case of malfunctioning it must be replaced as an assembly. When a car is brought in for service to the ignition system check first of all whether the trouble originates from the electronic unit or from the rest of the system.

This can be easily ascertained proceeding as follows:

- **after stopping the engine and removing the key from lockswitch** shift the lever of change-over switch 5, fig. 3, to position « **Emergency** », start the engine and check with a road test whether the conventional ignition system is efficient both at low and at high RPM rates.

IMPORTANT

Owing to the high voltages involved and to the peculiar characteristics of the electronic ignition unit, the following rules must be followed in case of servicing or checks:

- 1) **Never lay hands on the ignition system with engine running and key in lock switch.**
- 2) Never disconnect the battery with generator in operation otherwise the electronic ignition unit will be immediately ruined.
- 3) Check that electrical contact between battery posts and terminals is secure at all times.
- 4) In case of replacement of the electronic unit check that the new unit is securely grounded through its mounting bracket.
- 5) Should a radio set be mounted on the car never insert any condenser on the ignition coil.

- 6) The terminals of the cables from electronic unit to coil cap and from coil H.T. outlet to distributor are protected by boots (red) Cr, fig. 4, hermetically sealed with insulating compound (SILASTENE RTV 730).

It is once more emphasized that before laying hands on any part of the electronic ignition system, and particularly before uncovering the terminals protected by the red boots, the engine must be stopped and the key must be removed from lock switch since the terminals in question carry very high voltages.

Should these terminals have been uncovered for servicing they must be insulated perfectly again by filling the boots with « SILASTENE RTV 730 » insulating compound.

Fig. 4. - Detail of the « Dinoplex C » unit mounted on the DINO Coupé Model.

1. « Dinoplex C » unit - 2. Change-over switch for shifting from « **NORMAL** » to « **EMERGENCY** » ignition - 3. Ignition coil - 4. Relay switch for horns - D and + B. Terminals on ignition coil and corresponding identification marks on the leads from « Dinoplex C » - g. Lead with yellow identification mark - v. Lead with green identification mark - Cr. Red boots to be sealed with « SILASTENE RTV 730 » compound - R. Additional resistor.

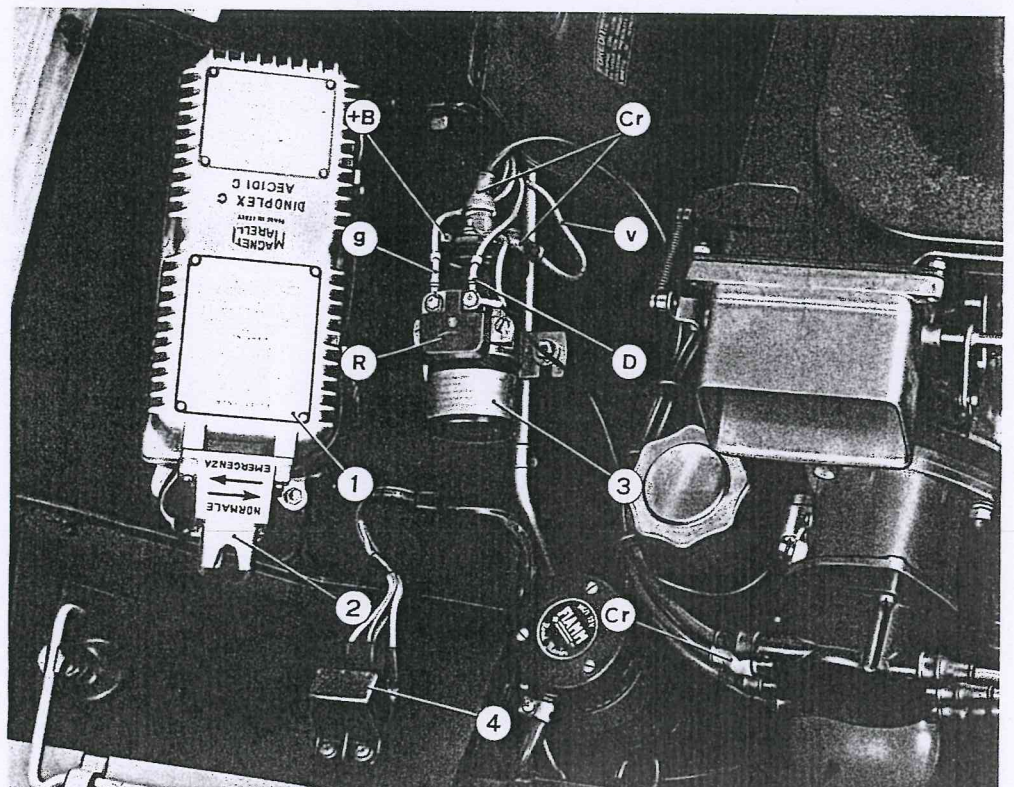

INSTRUCTIONS FOR « DINOPLEX C » INSTALLATION ON EARLY PRODUCTION COUPE AND SPIDER CARS

Operations common to both versions.

- 1) Disconnect battery positive terminal.
- 2) Replace the electronic tachometer with the one specific for « Dinoplex C » ignition system.
- 3) Replace the terminal boots (Cr, figs. 4 and 11) of the H.T. cable connecting the distributor to coil and of the cable with green collar connecting the ignition coil to the « Dinoplex C ». The new boots, of « red » color, must be filled with « SILASTENE RTV 730 » sealing compound before installation to ensure positive insulation.

Coupé.

- 1) Place jig M1, fig. 5, in the position shown in the figure and scribe line I, fig. 6, which marks the seating area (s) of the « Dinoplex C ».
- 2) Remove the jig and by proper hammering indent the sheet metal along the scribed line I, fig. 6, so as to produce a stiffening rib and to prepare a suitable seating plane for the « Dinoplex C » unit. By further hammering bend towards the engine a portion of the sheet metal lip, r, fig. 6, at the joining edge of the unit casing rear inboard corner.

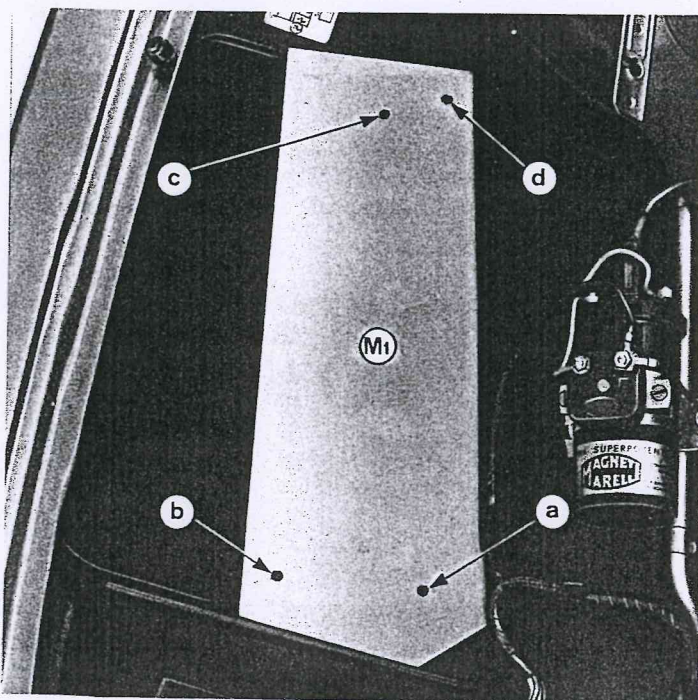

Fig. 5. - COUPÉ: position of jig M1 for scribing the « Dinoplex C » unit mounting holes a, b and c.

Hole d is used for positioning the jig on the Spider version.

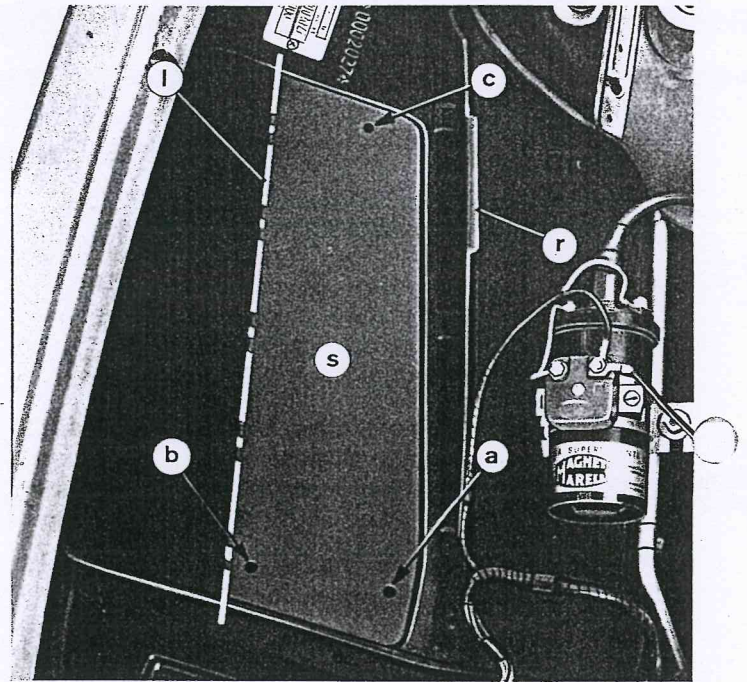

Fig. 6. - COUPÉ: adaptation and drilling of the « Dinoplex C » unit resting plane.

a, b, c. « Dinoplex C » fixing holes - I. Line marking plane s - s. Surface of the plane to be hammered - r. Portion of lip to be bent.

- 3) Position again the jig and scribe the three holes a, b and c, fig. 5. Remove the jig and drill 6,3 mm dia. holes a, b and c.

NOTE - On bench, chamfer at 45° over a width of 15-20 mm and over its entire length the upper corner of the unit casing (see fig. 7).

- 4) Install the « Dinoplex C » unit oriented as shown in fig. 4 and secure it with three screws inserted in the three holes a, b, c, fig. 6, from right wheelbox inner side.

- 5) Check that the clearance between engine compartment inner framing and casing top plane is not less than 12-15 mm. A quick check can be made by applying some putty in the minimum clearance spots between bonnet and unit and then lowering manually the bonnet so as to squeeze the putty. If the clearance (given by the thickness of the squeezed putty) is less than specified, remove the « Dinoplex C » and further deepen the unit seat by hammering as described in 2) above.

- 6) Replace the ignition coil and connect the leads in accordance with the wiring diagram of fig. 1.

«DINOPLEX C» DEVICE INSTALLATION TEMPLATES

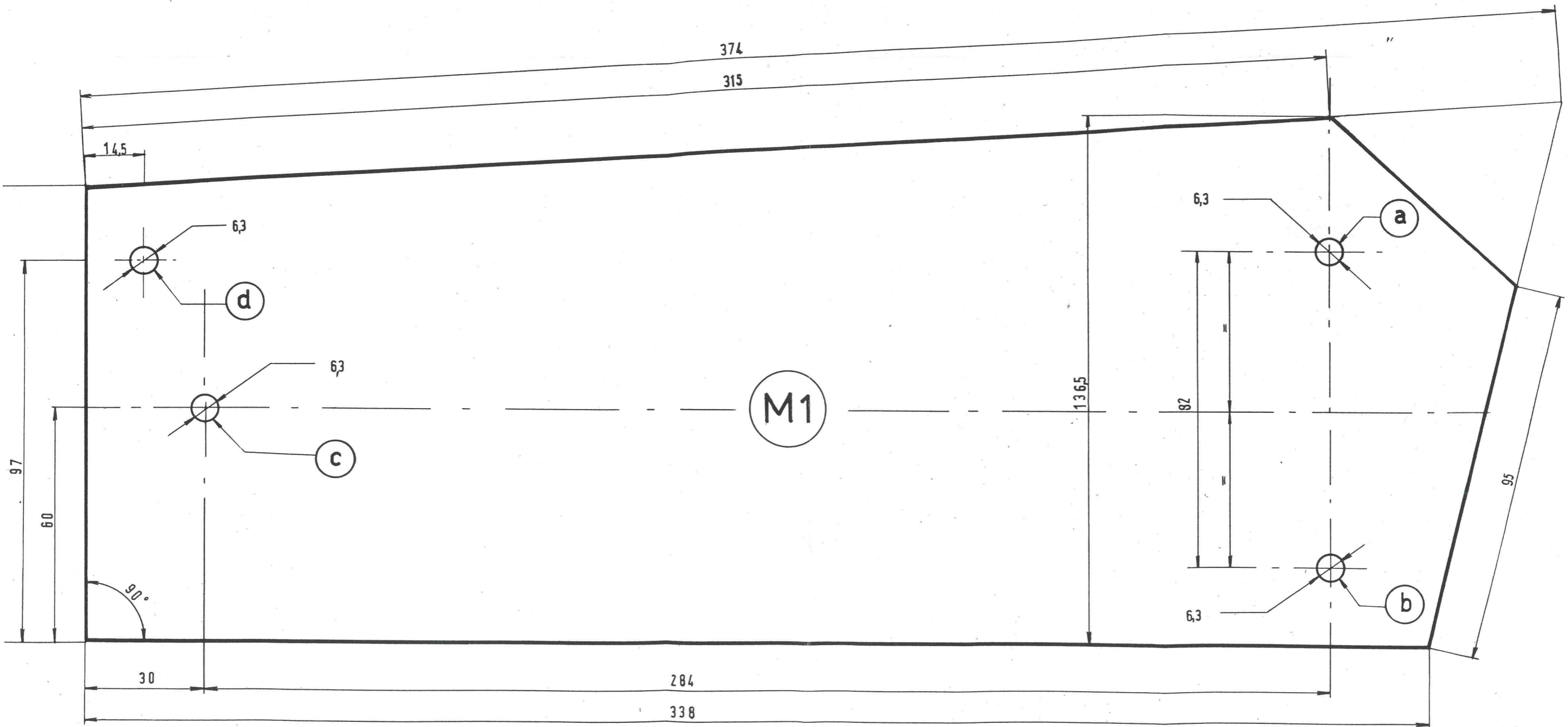

M1: This jig is in true scale and serves for both Coupé and Spider versions.

M2: This jig (to be used for the Spider version) is obtained from front plate No. 1903978 (see page 7) from which the three screws for «Dinoplex C» and ignition coil mounting screws must be cut off drilling three holes d, e and f in their place (see fig. 8).

NOTE: Above dimensions are in millimeters.

Fig. 7. - Diagram for chamfering the upper corner of « Dinoplex C » unit casing.

Normale = Normal
Emergenza = Emergency

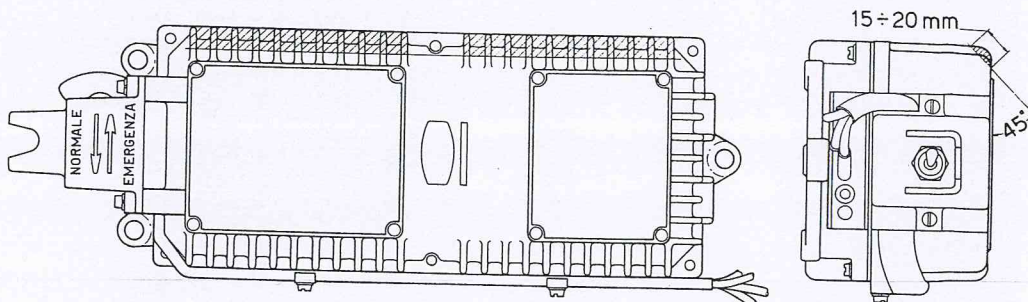

NOTE - On those cars where the horn relay switch interferes with the « Dinoplex C » installation relocate the switch in the position shown in fig. 4.

Spider.

- 1) Take off the bonnet. To ensure the subsequent correct reassembly mark the position of the right hand hinge.
- 2) Remove the horn compressor and relay switch.
- 3) Disconnect the servobrake line (4, fig. 8) from reservoir and take off the three clips holding the pipe on side rail.

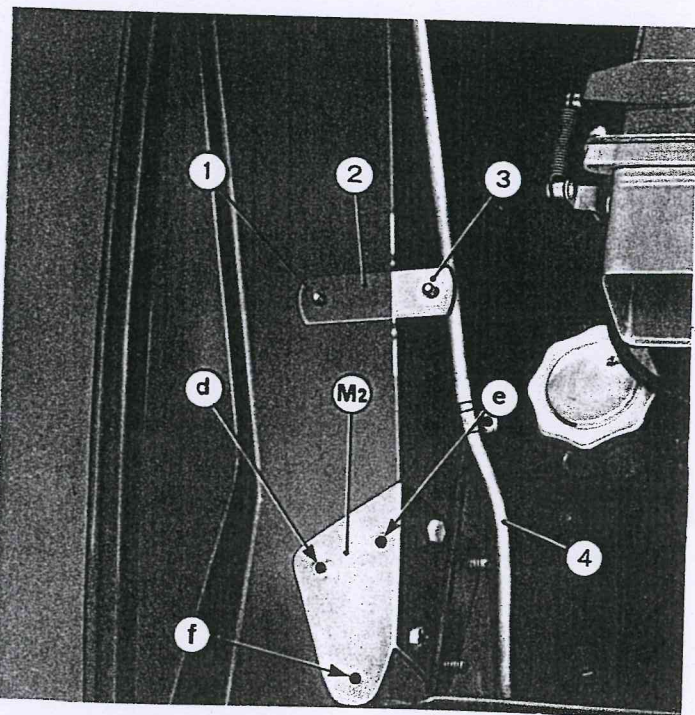

Fig. 8. - SPIDER: application of jig M2 for front plate positioning.

1. Stud to be sawn off - 2. Bracket for previous ignition coil mounting - 3. Wing of bracket 2, to be cut off - 4. Servobrake line - d and f. Holes on jig M2 for scribing the holes to be drilled in side rail.

- 4) Take off the ignition coil.
- 5) Cut off wing 3, fig. 8, and saw away stud 1, fig. 8, from bracket 2, fig. 8.

- 6) Position jig M2, fig. 8, locating it on the two compressor fixing screws and scribe the three holes d, e and f. Remove the jig and drill the holes using a 16 mm dia. edge hole saw (the use of this tool, is recommended to prevent chips from falling, inside the frame box-member).

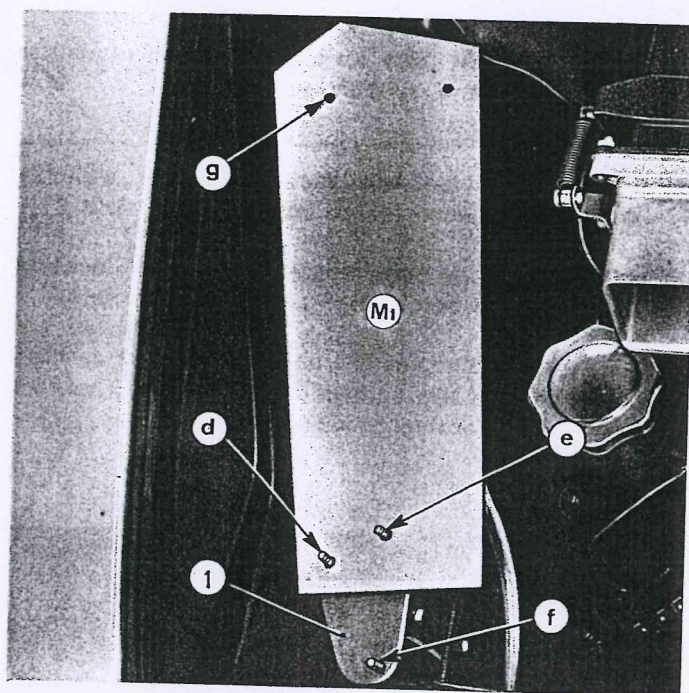

Fig. 9. - SPIDER: application of jig M1 for scribing hole g.

1. « Dinoplex C » front mounting plate - d, and e. Screws on plate 1 for jig M1 location - g. Hole in M1 for scribing the hole to be drilled in side rail - f. Ignition coil mounting screw on plate 1.

- 7) Adapt the vertical plane of front plate 1, fig. 10, to side rail flank and see that the heads of the three screws d, e and f, fig. 9, fit into the three holes previously drilled on side rail top face (see 6 above).
- 8) If required, slot slightly the two holes for screws 4, fig. 10, in order to correctly position the plate in relation to the existing pads on side rail inner flank (previously, said pads were used to mount the horn compressor).
- 9) Apply a coat of antirust paint on the plate inner side and then install the plate on side rail and

secure it with the two screws previously used to fix the horn compressor, after interposing two spacer washers between plate and side rail.

- 10) Apply jig M 1, fig. 9 (the same used for the Coupé) locating it by the two screws d and e as shown in fig. 9. Scribe hole g, fig. 9, remove the jig and cut the hole using a 16 mm dia. edge hole saw.
- 11) Position rear bracket 2, fig. 10, so that the screw head fits into hole g, fig. 9, and weld the plate to side rail with its edge at right angle to side rail corner (see fig. 10). Then, weld the front plate after checking that the « Dinoplex C » unit fits exactly on to the three screws e, f and g, fig. 9.
- 12) Stopper and paint all the engine compartment areas involved by the modification.
- 13) Install the horn relay switch in the new location (see fig. 11) and suitably arrange the connection leads.
- 14) Re-run the servobrake vacuum line by suitably modifying its bend in proximity of front plate.
- 15) Install the horn compressor in the new location using the two screws 5, fig. 10, on front plate.
- 16) Install the « Dinoplex C » unit and the new ignition coil using the two screws d and f, fig. 9. Connect the leads according to wiring diagram fig. 1.

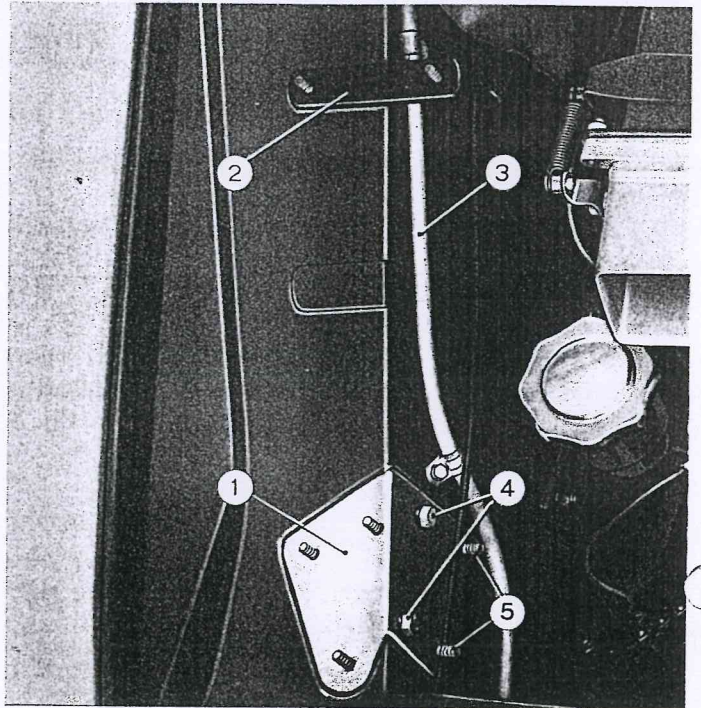

Fig. 10. - SPIDER: preparation for « Dinoplex C » installation.

1. Front plate - 2. Rear bracket - 3. Servobrake line - 4. Front plate fixing screw - 5. Horn compressor mounting screws on plate 1.

NOTE - Orient the ignition coil in such a position that terminal « + B » is as far as possible from the side of the « Dinoplex C » casing (see fig. 11).

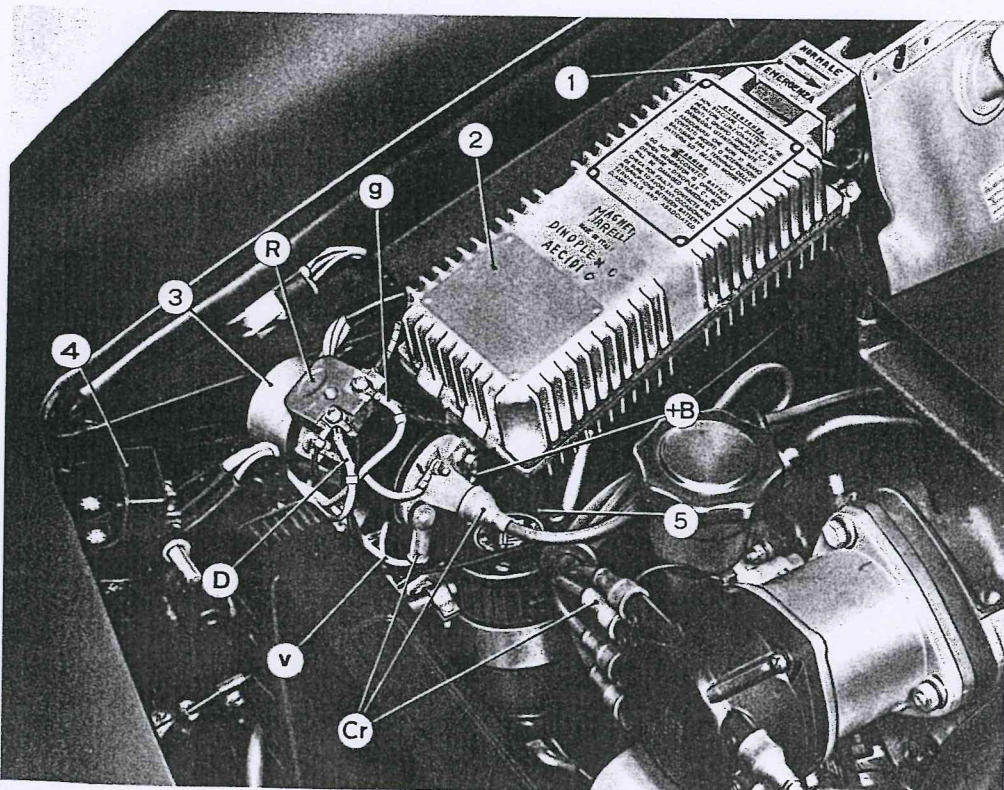

Fig. 11. - « Dinoplex C » unit installed on the DINO Spider.

1. Change-over switch for shifting from « NORMAL » to « EMERGENCY » ignition - 2. « Dinoplex C » - 3. Ignition coil - 4. Horn relay switch - 5. Horn compressor - D and + B. Terminals on coil and corresponding identification marks on the leads from « Dinoplex C » - g. Lead with yellow identification mark - v. Lead with green identification mark - Cr. Red boots to be filled with « SILASTENE RTV 730 » insulating compound - R. Additional resistor.

TESTING PROCEDURE FOR IGNITION SYSTEM WITH « DINOPLEX C » UNIT

After completing the installation of the « Dinoplex C » unit as specified above, test the system as follows:

- 1) Check that all cables are securely fixed and that the « Dinoplex C » and ignition coil are securely grounded through their mounting screws.
- 2) Check that the battery negative cable contact is secure and then reconnect the positive cable.
- 3) With key removed from lock switch set lever of change-over switch 2 (figs. 1-4 and 11) on « EMERGENCY » (conventional ignition) and start the engine. Only after ascertaining that operation is regular, stop the engine, remove the ignition key and shift the change-over switch to « NORMAL » (electronic ignition).

NOTE - Besides these instructions see also the directions under « IMPORTANT » on page 3.

MATERIALS REQUIRED

Qty.	ITEMS	Part No.
1	« Dinoplex C » unit	4191282
1	Ignition coil	4190859
1	Electronic tachometer	4190131 (**)
1	Electronic tachometer	4190132 (*)
2	Red boots (H. T.)	4192233
1	Red boot	4192234
5	Nuts, « Dinoplex C » and ignition coil fixing	1/58962/11
5	Lockwashers	1/26053/70
3	Screws, « Dinoplex C » unit fixing	1/09026/21 (**)
1	Plate, front	1903978 (*)
1	Bracket, rear	1903979 (*)
2	Washers, plate	1/26467/01 (*)
2	Washers, plate	1/26420/01 (*)
1	Tube, « SILASTENE RTV 730 », red boots sealing	—

(*) For Spider version - (**) For Coupé version.

Note - The items without asterisk (*) are common to both versions.

PRINTED IN ITALY

Print No. SAT 2211 - Norm. 502.173 - 2500 - VI-1968 - S.A.N. Torino